

Static and dynamic friction

MEASUREMENT OF FRICTION FORCES

- Comparison of static and dynamic friction.
- Measurement of how dynamic friction depends on the area in contact.
- Measurement of how dynamic friction depends on the combination of materials.
- Measurement of how dynamic friction depends on the perpendicular force between the two surfaces (normal force).

UE1020500

03/16 JS

BASIC PRINCIPLES

In order to move an object from rest along a level surface, a force of inertia needs to be overcome. This results from static friction between the body and the surface on which it rests. If, once moving the body is to continue sliding along the surface, a force of F_{Dyn} needs to be applied to overcome the dynamic friction. This force is smaller than the initial force needed to overcome the inertia caused by static friction F_{Stat} , as the degree of contact between the sliding body and the surface beneath is less.

Neither of these forces are dependent on the area in contact, instead being determined primarily by the types of materials and the roughness of the surfaces in contact. They are also proportional to the force that is pushing the surfaces together in a plane perpendicular to that of the surfaces themselves.

This is called the normal force F_N (it acts normally, i.e. perpendicular to the surface). The coefficients of static friction μ_{Stat} and dynamic friction μ_{Dyn} are thereby defined as in the following two equations:

$$(1) F_{\text{Stat}} = \mu_{\text{Stat}} \cdot F_N \text{ or } F_{\text{Dyn}} = \mu_{\text{Dyn}} \cdot F_N$$

In order to measure dynamic friction, an apparatus for measuring such friction is used, in which rough strips are pulled out at constant speed from under a body that remains stationary and is also connected to a dynamometer. Measurements are made for various combinations of materials and contact areas. To alter the normal force the track can be tipped up so that the component of the stationary body's weight that acts normally to the plane of the surface changes (see fig. 1).

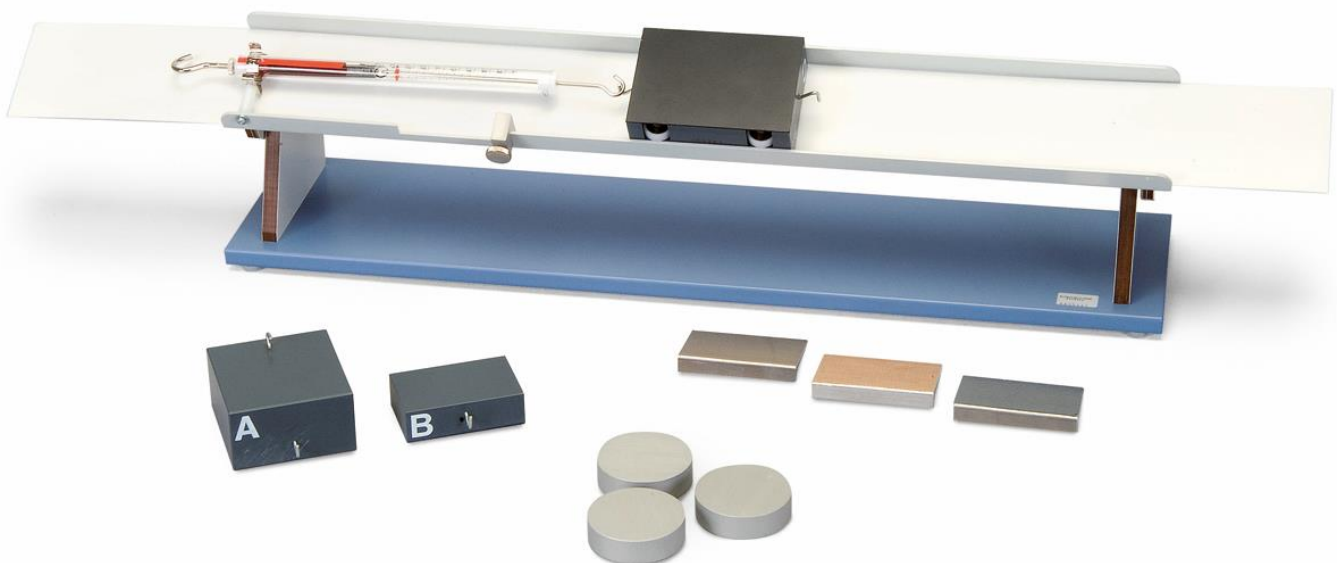

Fig. 1: Experiment set-up for investigating static friction and dynamic (sliding) friction.

LIST OF APPARATUS

- 1 Friction Measuring Apparatus 1009942 (U8405100)

SET-UP

- Set up the friction measuring instrument as described in the instruction sheet.
- Level the friction track horizontally.
- Check to ensure that the friction strip can be moved freely under the dynamometer fixing clamp.
- Fix the end-stop for the friction block to the edge of the track in such a position that the dynamometer cannot become unhooked when the friction strip is pulled back.

EXPERIMENT PROCEDURE

a) Comparison of static friction and dynamic friction:

- Place block A flat on the smooth surface of the friction strip and hook it to the dynamometer.
- To measure the static frictional force F_{stat} , pull the friction strip, carefully increasing the force, and record the maximum force that can be applied such that block A still remains in the same position on the friction strip.
- To measure the dynamic (sliding) frictional force F_{dyn} , pull out the friction band smoothly under block A and record the force indicated on the dynamometer.
- Repeat the measurements a number of times and check the reproducibility.

b) Measurement of dynamic frictional force as a function of the area of contact:

- Place block A flat on the smooth surface of the friction strip and measure the dynamic frictional force F_{dyn} .
- Place block A on its edge on the smooth surface of the friction strip and measure the dynamic frictional force F_{dyn} .
- Turn the friction strip over and repeat the measurements.

c) Measurement of dynamic frictional force for different combinations of materials:

- Place block B with its coated surface in contact with the smooth surface of the friction strip and measure the dynamic frictional force F_{dyn} .
- Place the uncoated aluminium angle piece – with its corner side facing the dynamometer – under block B and measure the dynamic frictional force F_{dyn} .
- Place each of the differently coated aluminium angle pieces under block B in turn and measure the dynamic frictional force F_{dyn} in each case.
- Turn the friction strip over and repeat the measurements.

d) Measurement of dynamic frictional force as a function of the force applied to the adjoining surfaces:

- Place block C with its coated surface in contact with the smooth surface of the friction strip and measure the dynamic frictional force F_{dyn} .
- Incline the friction track 10° from the horizontal, ensuring that the rollers of block C rest on the downward-sloping narrow side of the friction track (see fig. 2) and measure the dynamic frictional force F_{dyn} .
- Increase the slope of the track in 10° steps and measure the dynamic frictional force F_{dyn} in each case.

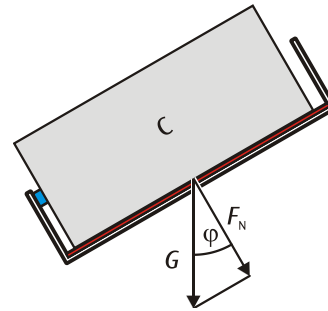

Fig. 2: Measurements with the friction track inclined.

SAMPLE MEASUREMENTS

a) Comparison of static friction and dynamic friction:

Table 1: Static frictional force F_{stat} and dynamic frictional force F_{dyn} on block A.

F_{stat} (N)	F_{dyn} (N)
1.20	1.10

b) Measurement of frictional force as a function of the area of contact:

Table 2: Dynamic frictional force F_{dyn} on block A for small and large areas of contact with smooth and rough friction strip surfaces.

Area	Friction strip	F_{dyn} (N)
Large	Smooth	1.10
Small	Smooth	1.10
Large	Rough	0.80
Small	Rough	0.80

c) Measurement of dynamic frictional force for different combinations of materials:

Table 3: Dynamic frictional force F_{dyn} on block B for different materials on smooth and rough friction strip surfaces.

Material	Friction strip	F_{dyn} (N)
Velour paper	Smooth	0.38
Aluminium	Smooth	0.50
Plastic 1	Smooth	0.26
Plastic 2	Smooth	0.80
Velour paper	Rough	0.60
Aluminium	Rough	0.24
Plastic 1	Rough	0.20
Plastic 2	Rough	0.84

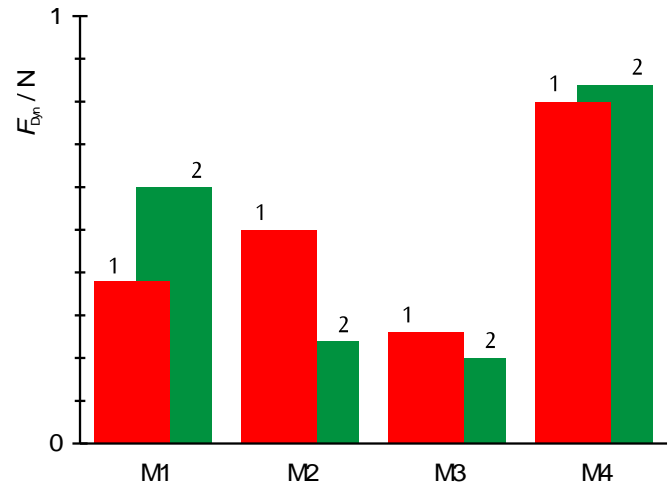

Fig. 3: Dynamic friction F_{dyn} for four different materials on a smooth surface (1) and a rough surface (2).

d) Measurement of dynamic frictional force as a function of the force applied to the interface:

Table 4: Dynamic frictional force on block C as a function of the angle of slope of the friction track.

φ	F_{dyn} (N)	$m g \cos \varphi$ (N)
0	1.88	3.15
10	1.78	3.10
20	1.70	2.96
30	1.60	2.73
40	1.44	2.41
50	1.24	2.02
60	0.84	1.57
70	0.70	1.08

d) Measurement of dynamic frictional force as a function of the force applied to the adjoining surfaces:

The force F_N acting on the friction strip due to the weight of the block with an angle of slope φ is:

$$F_N = m \cdot g \cdot \cos \varphi$$

In table 4 the force is calculated for a mass $m = 320$ g. Figure 4 shows the measured dynamic frictional force as a function of the force pressing the surfaces together, calculated as in the table. There is a good fit to a straight line through the origin with a gradient $\mu_{dyn} = 0.59$, in agreement with equation 1.

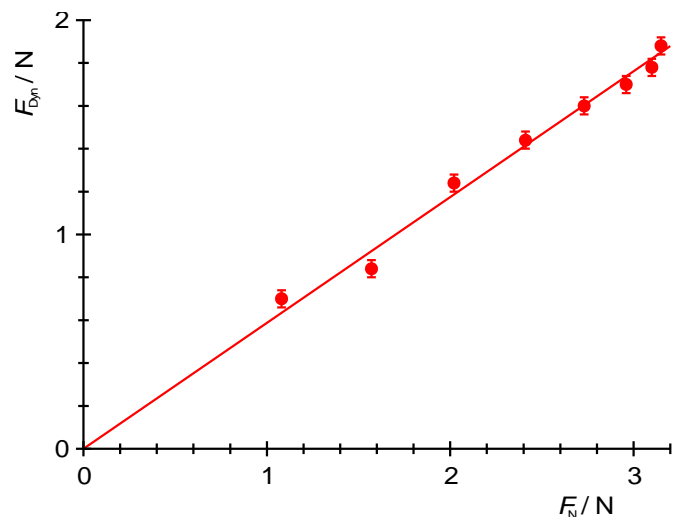

Fig. 4: Dynamic frictional force F_{dyn} as a function of the force F_N between the adjoining surfaces

EVALUATION

a) Comparison of static friction and dynamic friction:

The static frictional force F_{stat} is greater than the dynamic frictional force F_{dyn} (see table 1).

b) Measurement of dynamic frictional force as a function of the area of contact:

The dynamic frictional force is independent of the area of contact if all other conditions are the same (see table 2).

c) Measurement of dynamic frictional force for different combinations of materials:

The dynamic frictional force depends greatly on the combination of the materials of the two surfaces in contact (see table 3 and fig. 3).